

# **HARE & FORBES**

## **MACHINERYHOUSE**

Established 1930

Distributors of new & used workshop Equipment

S761 1300 x 2.5

S7615 1300 x 4.5

S762 1300 x 6.5

PLATE ROLLS

**INSTRUCTION & PARTS MANUAL**

6-4-11

# **ELECTRIC SLIP ROLL MACHINE**

**Model: ESR-1300X2.5/ESR-1300X4.5**

**ESR-1300X6.5/ESR-1550X3.5**

**ESR-2020X3.0/ESR-2070X2.5**

**ESR-2070X3.5/ESR-2500X0.8**



***Operation Manual***

# Table of contents

<b>I MAIN SPECIFICATION.....</b>	<b>2</b>
<b>II SAFETY INSTRUCTIONS.....</b>	<b>Page 2</b>
<b>III OPERATION INSTRUCTIONS.....</b>	
<b>IV ELECTRIC SYSTEM.....</b>	<b>Page 4</b>
<b>V PARTS DRAWING AND LIST .....</b>	<b>Page 6</b>
<b>VI Parts list.....</b>	<b>Page 7</b>

## I MAIN SPECIFICATION

MODEL	ESR-1300X2.5	ESR-1300X4.5	ESR1300X6.5	ESR-1550X3.5
Max rolling width	1300mm	1300mm	1300mm	1550mm
Max rolling thickness	2.5mm	4.5mm	6.5mm	3.5mm
Rolling diameter	90mm	120mm	150mm	120mm
Rotate speed	22rpm	16.5rpm	15rpm	16.5rpm
Motor Power	1.5kW	2.2kW	4KW	2.2kW
Overall dimension	180x64x100cm	181x64x105cm	230X80X134cm	206x64x105cm
Weight	470kg	660kg	1190kg	750kg
MODEL	ESR-2020X3.0	ESR2070X2.5	ESR2070X3.5	ESR2500X0.8
Max rolling width	2020mm	2070mm	2070mm	2500mm
Max rolling thickness	3.0mm	2.5mm	3.5mm	0.8mm
Rolling diameter	127mm	120mm	127mm	90mm
Rotate speed	16.5rpm	16.5rpm	16.5rpm	17.5rpm
Motor Power	4.0kW	2.2kW	4.0kW	1.5KW
Overall dimension	253x64x105cm	282X90X140	282X100X145cm	312X76X130cm
Weight	950kg	1250kg	1300kg	950kg

## II SAFETY INSTRUCTIONS

**Save this manual:** You will need the manual for the safety warnings and precautions, assembly instructions, operating and maintenance procedures, parts list and diagram. Keep your invoice with this manual. Keep the manual and invoice in a safe and dry place for future reference.

**WARNING: FAILURE TO FOLLOW THESE RULES MAY RESULT IN SERIOUS PERSONAL INJURY** As with all machinery there are certain hazards involved with operation and use of the machine. Using the machine with respect and caution will considerably lessen the possibility of personal injury. However, if normal safety precautions are overlooked or ignored, personal injury to the operator may result.

This machine was designed and constructed for roll forming metal plate and some similar material. We strongly recommend that this machine SHOULD NOT be modified and/or used for any application other than for which it was designed. If you have any questions about its application, do not use the machine until you contact with us and we have advised you.

Read all instructions before using this tool!

## 1. MACHINERY GENERAL SAFETY WARNINGS

- 1) Misuse of this machine can cause serious injury. For safety, machine must be set up, used and serviced properly. Read, understand and follow instructions in the operator's and parts manual which was shipped with your machine.
- 2) Wear proper apparel. No loose clothing or jewelry which can get caught in moving parts. Gloves and rubber soled footwear is recommended for best footing.
- 3) Do not overreach. Failure to maintain proper working position can cause you to fall into the machine or cause your clothing to get caught — pulling you into the machine.
- 4) Keep guards in place and in proper working order. Do not operate the machine with guards removed.
- 5) Avoid dangerous working environments. Do not use stationary machine tools in wet or damp locations. Keep work areas clean and well lighted
- 6) Avoid accidental starting. Make sure switch is in “**OFF**” position before plugging in power cord
- 7) Never leave the machine running while unattended. Machine shall be shut off whenever it is not in operation.
- 8) Disconnect electrical power before servicing. Whenever changing accessories or general maintenance is done on the machine, electrical power to the machine must be disconnected before work is done.
- 9) Machinery must be anchored to the floor.
- 10) Use the right tool. Know the tool you are using — its application, limitations, and potential hazards. Don't force a tool or attachment to do a job it was not designed for.
- 11) Stay alert Watch what you are doing; use common sense. Do not operate any tool when you are tired. Keep hands in sight and clear of all moving parts and rolling surfaces.
- 12) Keep children away. Children must never be allowed in the work area. Do not let them handle machines, tools, or extension cords.
- 13) All visitors should be kept at a safe distance from the work area. Make workshop completely safe by using padlocks, master switches, or by removing starter keys.
- 14) Store idle equipment. When not in use, tools must be stored in a dry location to inhibit rust. Always lock up tools and keep out of reach of children.
- 15) General Electrical Cautions :This machine should be grounded in accordance with the National Electrical Code and local codes and ordinances. This work should be done by a qualified electrician. The machine should be grounded to protect the user from electrical shock.

## **2. TRANSPORTATION (CRANE OR FORKLIFT ID RECOMMEND)**

- Transportation before un-packing
  1. The steel wire of crane should be capable of lifting weight over 2000 kgs.
  2. The steel wire must be arranged properly as per cavity center of wooden box.
  3. The crane ( or forklift) operator should be a qualified & trained person.
  4. Machine should be loaded at the cavity center of truck to avoid any sliding.
  5. After loading onto truck, use steel wire to fix the machine body on truck and ensure to fasten it firmly before transportation.

## **3. POSITIONING & CLEANING**

- Site : When select site, ensure there is free space for material handing around the machine.
- Foundation: The machine requires a plane & stable ground to have an excellent bending performance. It is better to fixed on 150mm reinforced concrete ground.
- Leveling: Four sheet shims are placed under the adjusting bolt of foot plate, the machine is leveled by level gauge.
- Cleaning: Use a liquid solvent such as kerosene or white spirit to remove the protective coating and any dirt from the up-painted surface of the machine. Don't disturb any moving parts until all surface has been cleaned.

## **4. ELECTRIC CONNECTION**

- Before connecting machine into local 3-phase ac source at your plant, please double check same voltage and phase.
- Connect the ac source with machine cable which has 4 wires, correctly, the ground wire must to be connected with ground.
- After connecting ac source to shaft motor rotation is in the correct rotation direction as per the arrow on the motor.
- If wrong direction, please immediately stop motor to avoid motor damage. Please correct your connecting at ac source until motor rotation direction is in correct direction.

# **III OPERATION INSTRUCTIONS**

## **1. HOW TO ROLL FORMING CIRCLE**

- 1) Length of material – necessary to form the designed size circles is the 1<sup>st</sup> consideration in circle forming. Decide approximate length of material need. Use the formulary “ $C = \pi \times ID$ ”(C is Circumference;  $\pi$  is 3.1416; ID is Internal Diameter).

Sample:ID=200mm, operator need to prepare material length approximate 630.32mm or approximate length of material which need.

- 2) Cut a few pieces of material to the measured length for testing by roll forming. The material might need to be lengthened or shortened depending upon the

testing result.

- 3) Loosen the clamping screws to the right position which operator can insert the material between upper roll and bottom roller, then fasten the clamping screws to ensure upper roller and bottom roller clamp in proper pressure.
- 4) Set the idle roller to same height of bottom roller.
- 5) Power on the foot switch to move the material between upper roller and bottom roller forwardly to ensure the front-side material of measured length to pass through the idle roller. (Drawing No.01)
- 6) Ensure the rear end-side material to reach between the upper roller and bottom roller. (Drawing No.02)
- 7) Raise the idle roller bend forming the end-side material to designed angle to complete the pre-bending at the rear end-side of measured length. (Drawing No.03 &04).
- 8) Remove the material which has seen completed pre-bending at rear end-side to be the expected diameter.
  
- 9) Repeat same step of No.3-7 (Drawing No.5-6) but pre-bend at the frontal end-side material.
- 10) Down the idle roller as soon as the material has been pre-bend at the end side of frontal and rear to be the expected diameter.(Drawing No.7)
- 11) Raise the idle roller step by step when the upper roller and bottom roller to form the material to be circular between frontal and rear end-side.(Drawing No.8 & 9)
- 12) If the finished sample is not long enough or if the formed part is not the proper diameter, additional samples will have to be made. Thousands of identical parts can be precisely duplicated when proper adjustments of the roller have been made.
- 13) Get the correct modifying and forming after testing the few pieces to file your record for official forming.
- 14) The same diameter as the diameter of the rolls and slightly larger can be formed. To make the adjustment for the material thickness and to determine the material length needed and the illustration given under above-mentioned step No.1~9.

2. PROCESS DRAWING OF ROLL FORMING

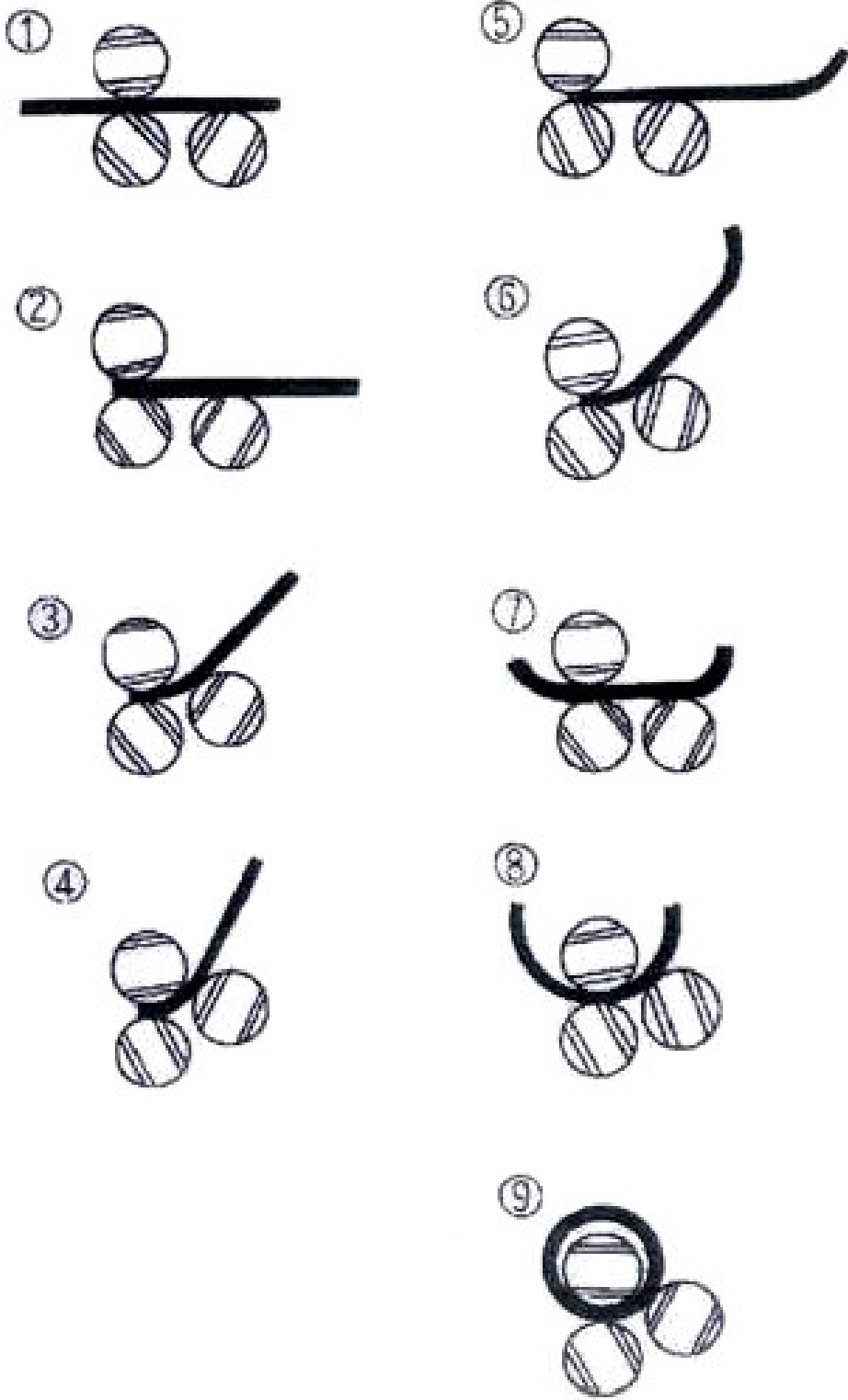

### 3. ADJUSTING THE CLAMPING (BOTTOM) ROLLER & PINCHING (IDLE) ROLLER

- 1) The adjusting handwheel mounted on the right-hand side frame of the machine construction can adjust the bottom roller to clamp material tightly.
- 2) The hand wheel is mounted on right-hand side frame of machine construction enable the operator to raise or lower the idle (pinch) roll, so the correct gap between the upper and idle (pinch) rolls may be obtained to feed the designed stock into the machine.

### 4. REMOVE THE FORMED MATERIAL

Lift clamp handle and slide the support lever handle to the right. The pinch roll will rise. Slide the finished sample off the roll.

### 5. ILLUSTRATION / OPERATION OF CONE BENDING ATTACHMENT

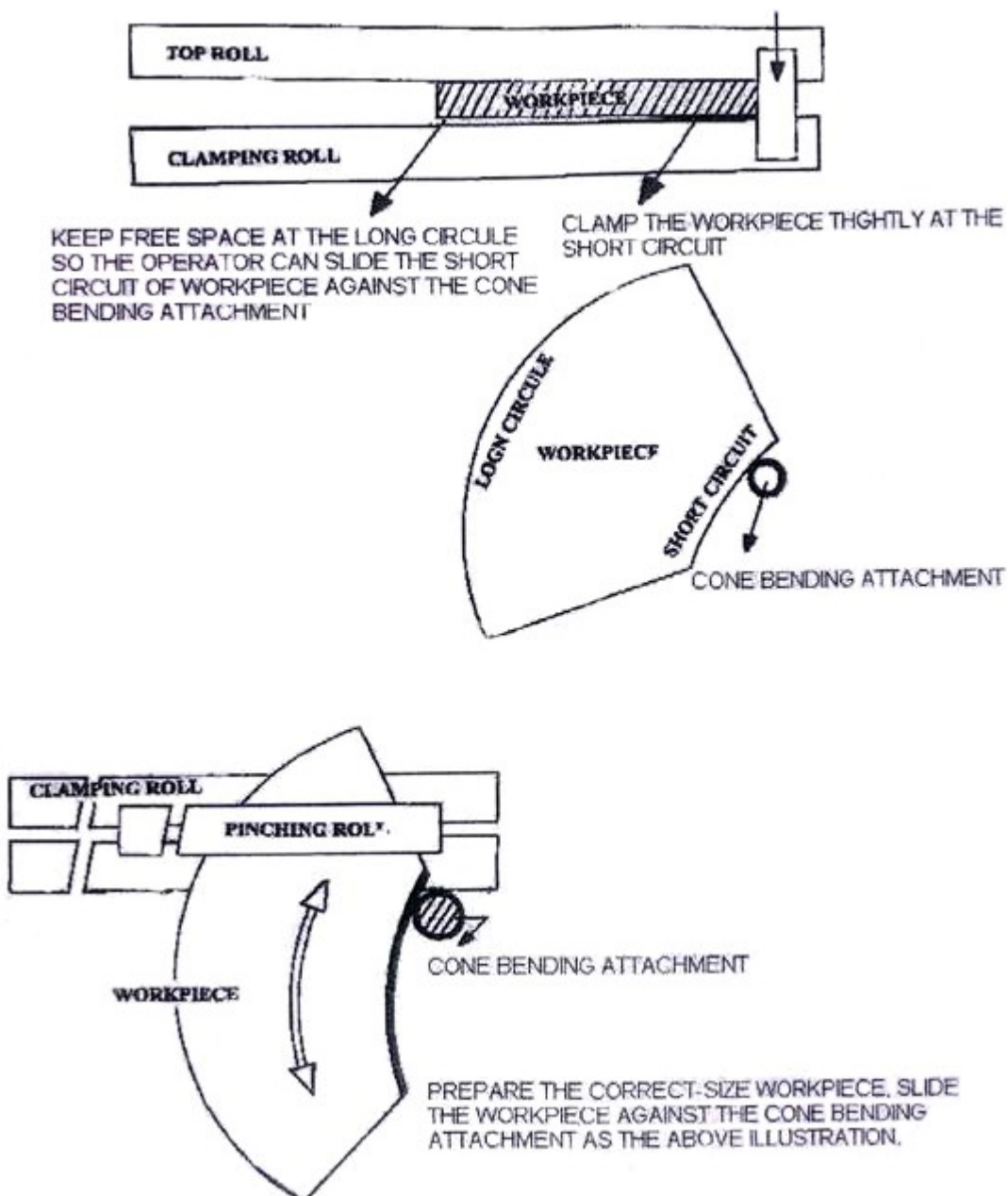

## 6. ILLUSTRATION / OPERATION OF SIMULTANEOUS CLAMPING ROLLER

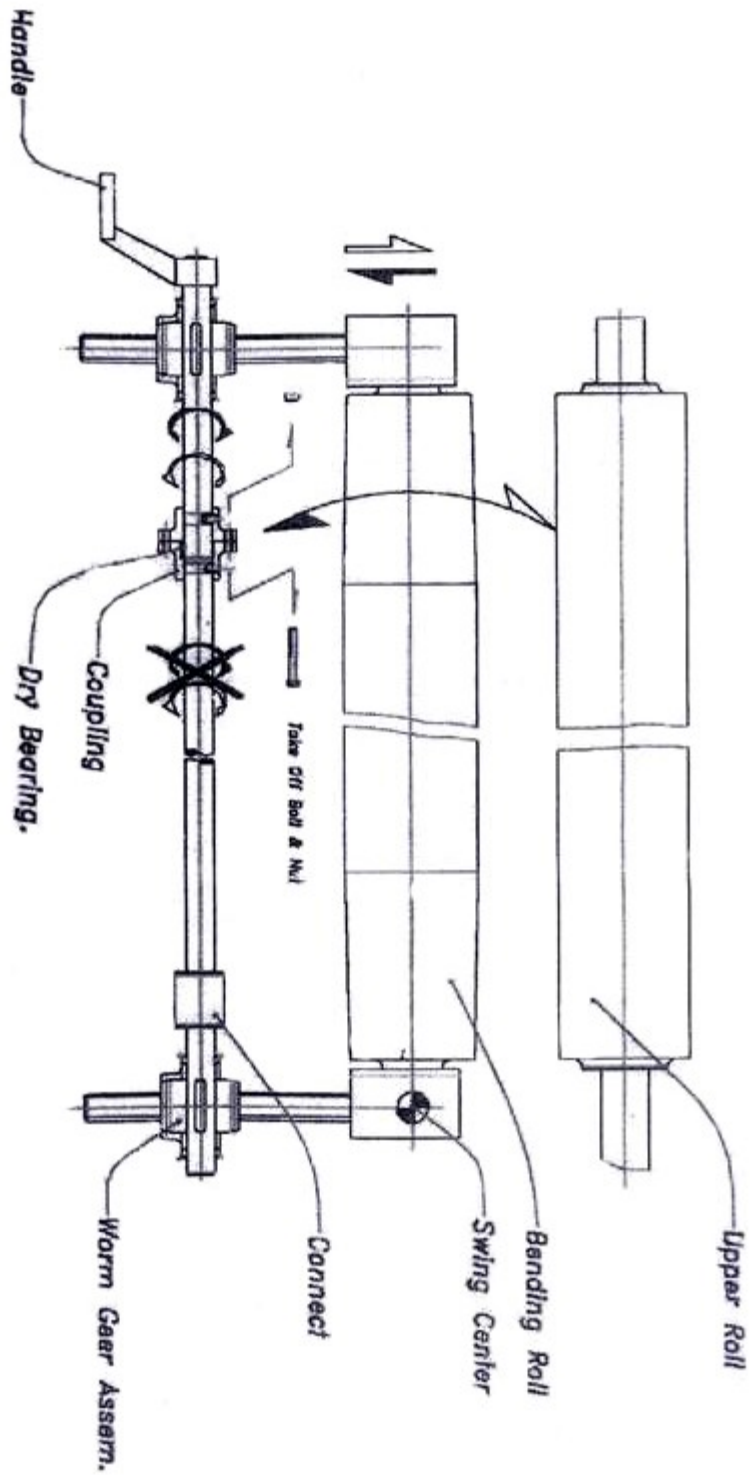

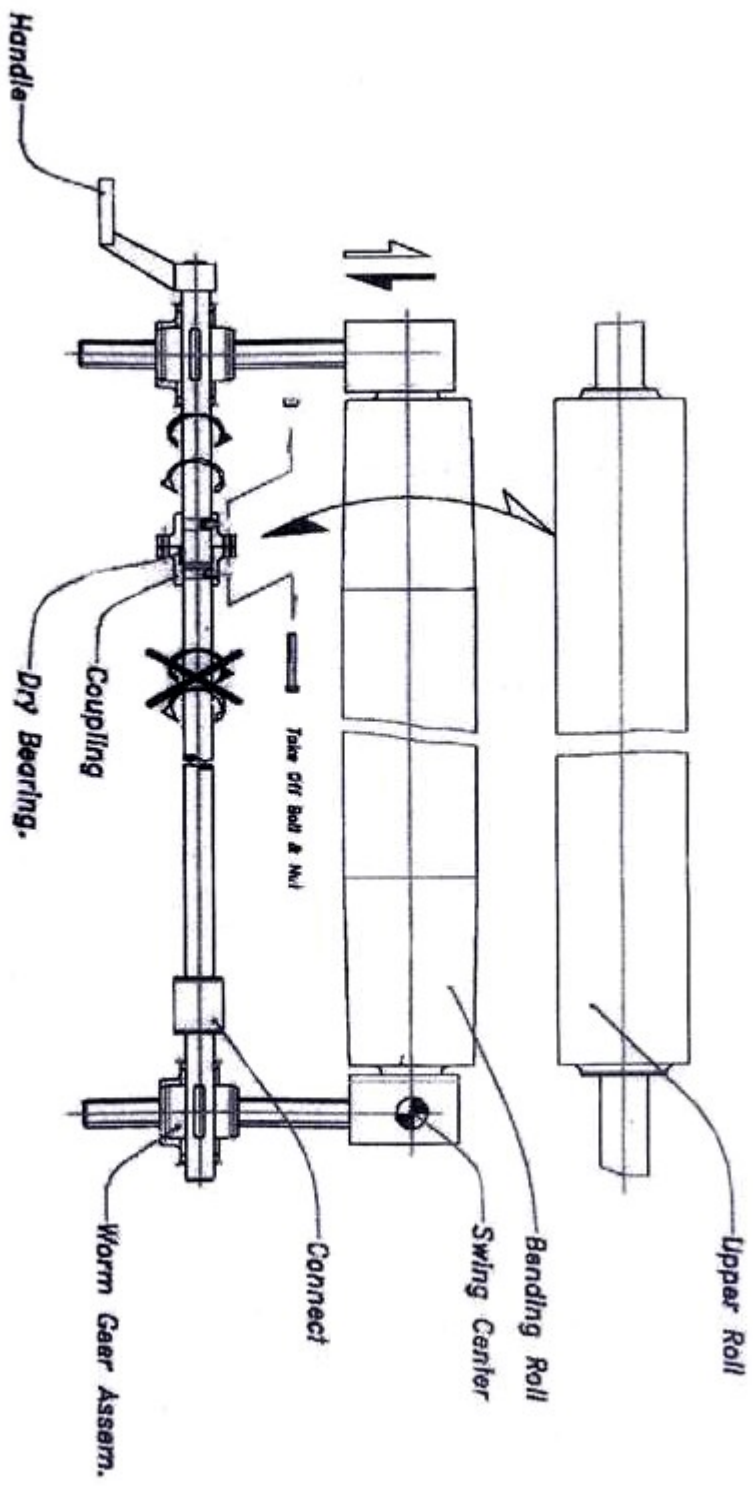

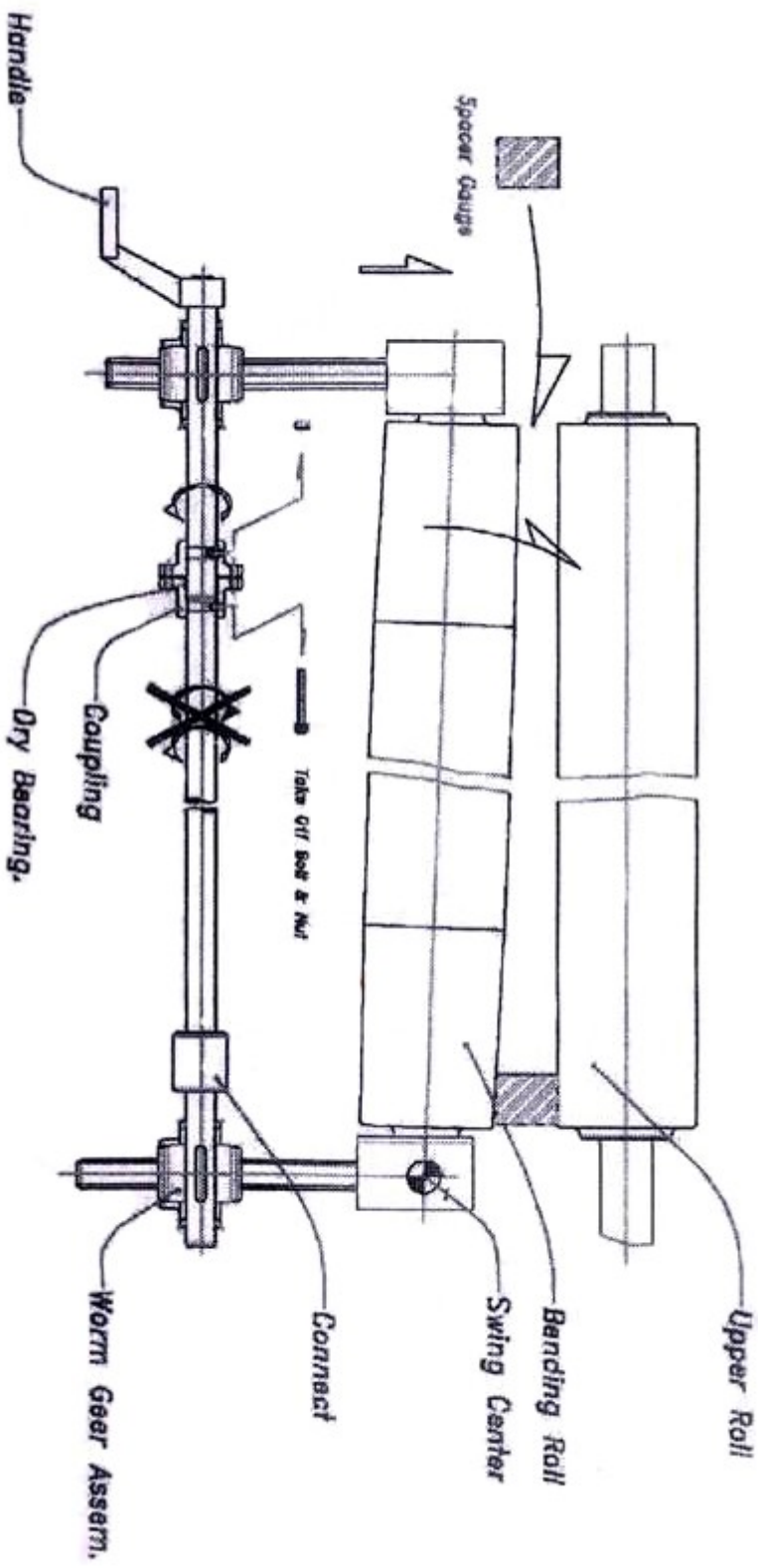

## IV ELECTRIC SYSTEM

1, Preparation :The consumer should prepare a 10A power switch. Connect 3x4 mm<sup>2</sup> + 1x4mm<sup>2</sup> yellow/green with the power switch. The earth-line should be connected with the earth-plate.

### 2, Operation of the machine

Combine the breaker in the electric appliance box and turn right the power switch. At this time the indicator lighted, which means the machine had been connected with power correctly. Pedal down the right starting pedal, the machine rolls clockwise continuously until loosen the pedal. Pedal down the left starting pedal, the machine rolls on the contrary of the above direction. If there is some wrong with the machine, push the emergency switch on the handle to stop the machine. After the trouble is solved, turn off the switch to work.

### 3, Maintenance of the machine

The machine has a compact structure. It is easy to be operated and maintained. Some problems maybe exist as follows:

- 1) The indicator lights, the machine can't work when pedal down the starting pedal, then turn off the emergency switch on the handle.
- 2) The indicator doesn't light, then combine the breaker in the electric appliance box.
- 3) The indicator lights and the spindle works, but motor doesn't work, that means the connecting wire is loose or disconnected.

### 4, Electric principle drawing (refer to the attached drawing)

### 5, Main electric appliance list

No.	Symbol	Name
1	LW	Power switch
2	QF	Breaker
3	TC	Transformer
4	KM	Alternating contactor
5	EL	Indicator light
6	TA	Lash-up switch
7	M	Motor

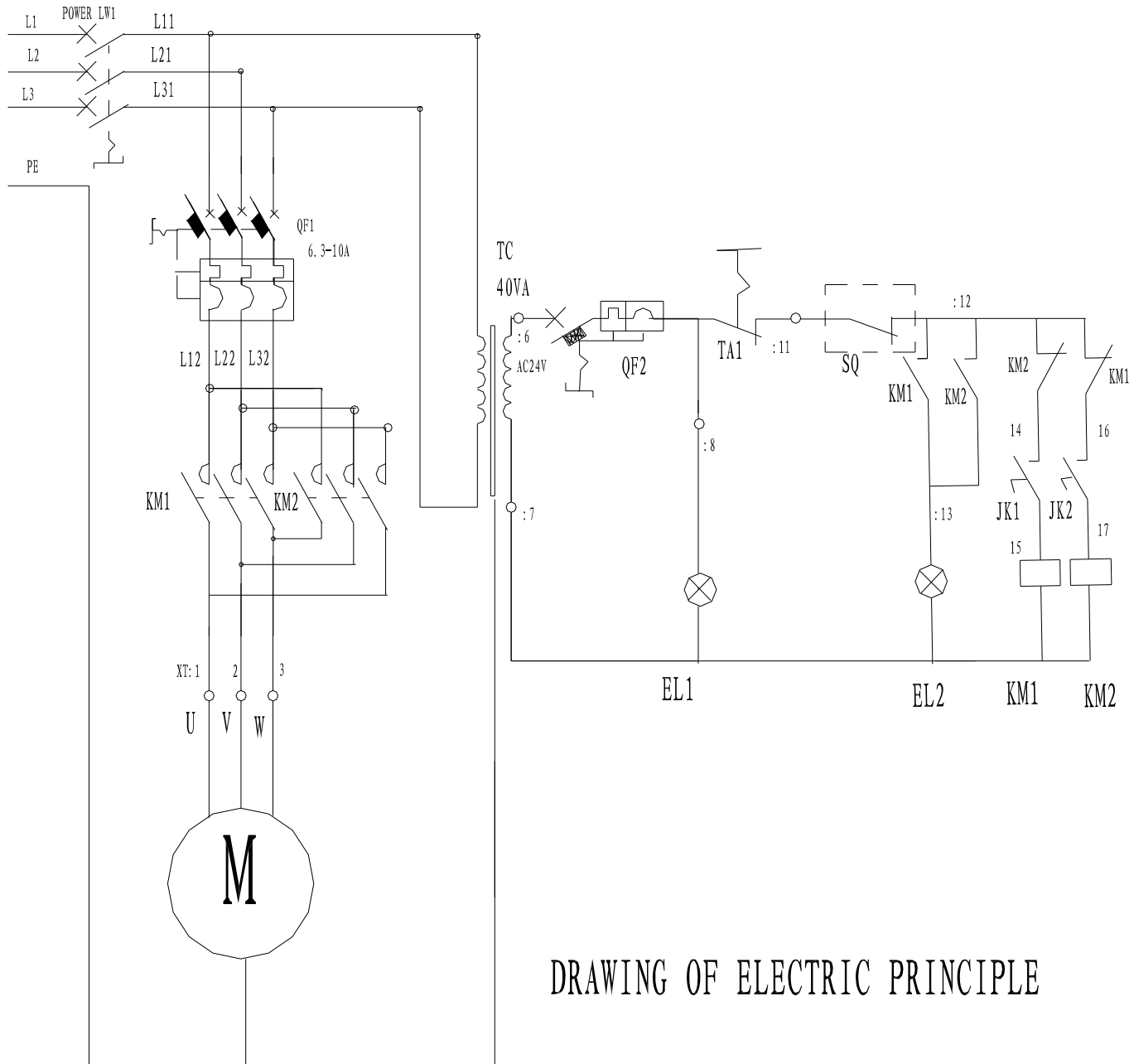

DRAWING OF ELECTRIC PRINCIPLE

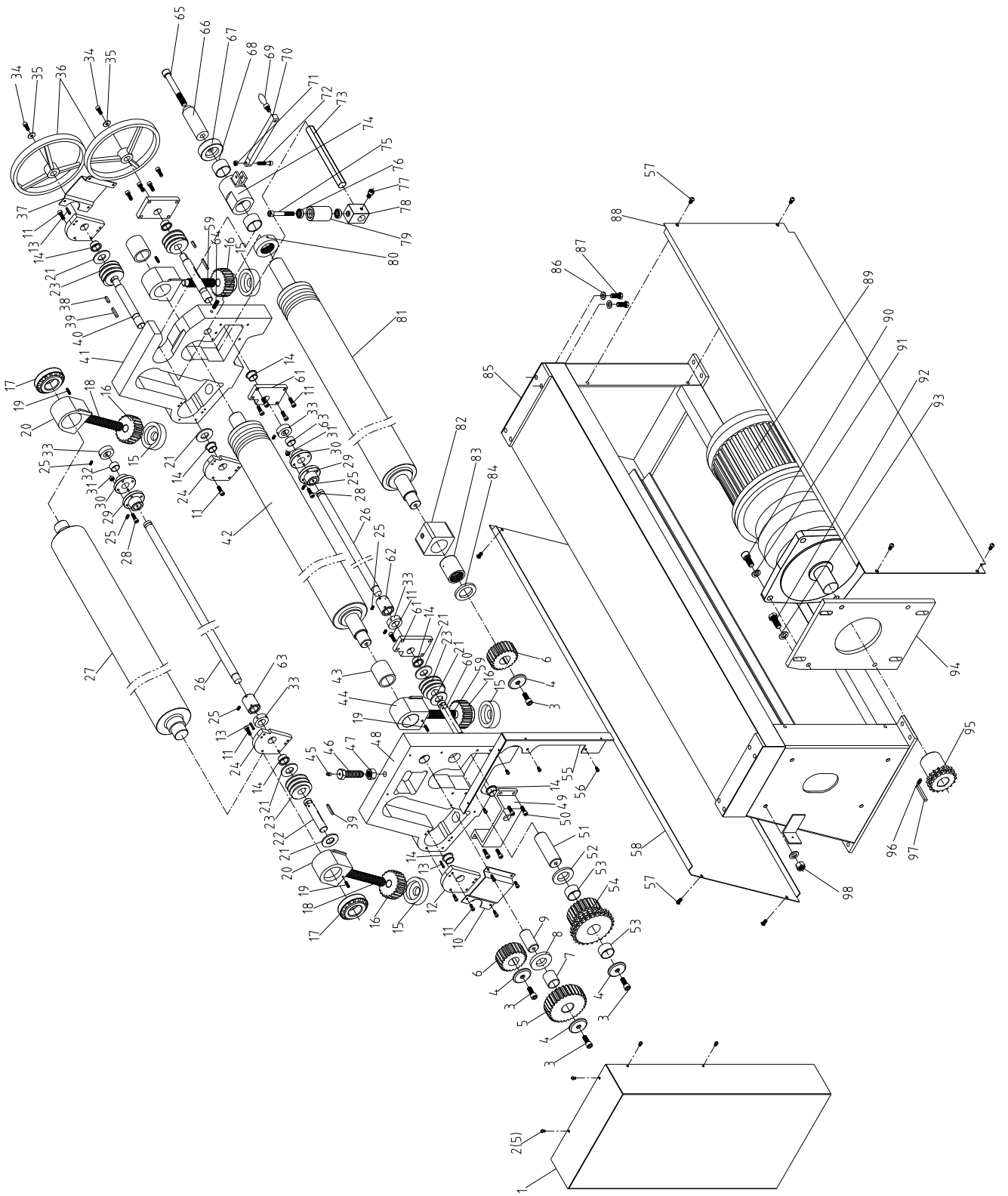

## PARTS LIST

Part #	Description	Q'ty	Part #	Description	Q'ty
1	Protecting Cover	1	40	Fixed Shaft	1
2	Hex Bolt M6X10	5	41	Right frame	1
3	Bolt M12X30	3	42	Pitch (idle) roller	1
4	Mat	3	43	Sleeve	2
5	Big gear	1	44	Adjusting block	2
6	Small gear	2	45	Oli cup	1
7	Bushing	1	46	Bolt	1
8	Washer	1	47	Nut M20	1
9	Shaft	1	48	Left frame	1
10	Block plate	1	49	Supporting plate	1
11	Hex Bolt M6X16	28	50	Hex Bolt M8X25	4
12	fixed plate	1	51	Shaft	1
13	Spring pin	2	52	Washer	1
14	Bushing	8	53	Bushing	2
15	Supporting bushing	3	54	Chain wheel	1
16	Worm wheel	3	55	Connecting plate	1
17	Bearing	2	56	Bolt M6X12	4
18	Screw rod	2	57	Bolt M8X16	8
19	Locking bolt M6X25	4	58	Cover plate	1
20	Adjusting block	2	59	Small screw rod	1
21	Washer	8	60	Connecting shaft	1
22	Washer	1	61	Block plate	2
23	Worm shaft	4	62	Connecting bushing	2
24	Block Plate	2	63	Bushing	1
25	Locking bolt M6X30	20	64	Locking bolt M10X30	1
26	Connecting shaft	2	65	Hex bolt M16X30	1
27	Upper roller	1	66	Handle	1
28	Hex Bolt M6X30	8	67	Connecting bushing	1
29	Connecting bushing	2	68	Bushing	2
30	Connecting bushing	2	69	Swivel handle	1
31	Nut M6	8	70	Pole of Handle	1
32	Bushing	1	71	Locking Nut M8	1
33	Connecting bushing	3	72	Hex bolt M8X45	1
34	Hex Bolt M8X20	2	73	Shaft	1
35	Sleeve	2	74	Locking bushing	1
36	Handle wheel	2	75	Hex bolt M12X50	1
37	Block plate	1	76	Bearing	2
38	Key 8x25	2	77	Hex bolt M10X16	1
39	Key 8x45	2	78	Sliding block	1

79	Limited block	1	89	motor	1
80	Sliding sleeve	1	90	Hex bolt M16X35	4
81	Lower (clamping)roller	1	91	Spring washer 16	4
82	Adjusting block	1	92	Bolt M16X40	4
83	Sleeve	1	93	Washer 16	8
84	Mat	1	94	Plate for motor	1
85	stand	1	95	Small chain wheel	1
86	Nut M12	8	96	Locking Bolt M8X16	2
87	Bolt M12X30	8	97	Key	1
88	Block plate	1	98	Nut M16	4

# EC Declaration of Conformity

Manufacture:

Company name: TENGZHOU TRI-UNION MACHINERY CO., LTD.

**Address: No. 318 South Yikang Road, Tengzhou city Shandong,**

**China P.C: 27500**

Hereby declare, that

Machine:

Model No: ESR-1300X2.5/ESR-1300X4.5

ESR-1550X3.5/ESR-2020X3.0

Name: ELECTRIC SLIP ROLL

Is in conformity with the norms, machine directive (89/392/CE,91/368 EEC)

Company:

Date: 2007-12-26

**Note:** This manual is only for your reference. Owing to the continuous improvement of the machine, changes may be made at any time without obligation on notice. And please note the local voltage while operating this electric machine.

# WARNING

## General Machinery Safety Instructions

---

Machinery House  
requires you to read this entire Manual before using this machine.

- 1. Read the entire Manual before starting machinery.** Machinery may cause serious injury if not correctly used.
- 2. Always use correct hearing protection when operating machinery.** Machinery noise may cause permanent hearing damage.
- 3. Machinery must never be used when tired, or under the influence of drugs or alcohol.** When running machinery you must be alert at all times.
- 4. Wear correct Clothing.** At all times remove all loose clothing, necklaces, rings, jewelry, etc. Long hair must be contained in a hair net. Non-slip protective footwear must be worn.
- 5. Always wear correct respirators around fumes or dust when operating machinery.** Machinery fumes & dust can cause serious respiratory illness. Dust extractors must be used where applicable.
- 6. Always wear correct safety glasses.** When machining you must use the correct eye protection to prevent injuring your eyes.
- 7. Keep work clean and make sure you have good lighting.** Cluttered and dark shadows may cause accidents.
- 8. Personnel must be properly trained or well supervised when operating machinery.** Make sure you have clear and safe understanding of the machine you are operating.
- 9. Keep children and visitors away.** Make sure children and visitors are at a safe distance for you work area.
- 10. Keep your workshop childproof.** Use padlocks, Turn off master power switches and remove start switch keys.
- 11. Never leave machine unattended.** Turn power off and wait till machine has come to a complete stop before leaving the machine unattended.
- 12. Make a safe working environment.** Do not use machine in a damp, wet area, or where flammable or noxious fumes may exist.
- 13. Disconnect main power before service machine.** Make sure power switch is in the off position before re-connecting.
- 14. Use correct amperage extension cords.** Undersized extension cords overheat and lose power. Replace extension cords if they become damaged.
- 15. Keep machine well maintained.** Keep blades sharp and clean for best and safest performance. Follow instructions when lubricating and changing accessories.
- 16. Keep machine well guarded.** Make sure guards on machine are in place and are all working correctly.
- 17. Do not overreach.** Keep proper footing and balance at all times.
- 18. Secure workpiece.** Use clamps or a vice to hold the workpiece where practical. Keeping the workpiece secure will free up your hand to operate the machine and will protect hand from injury.
- 19. Check machine over before operating.** Check machine for damaged parts, loose bolts, Keys and wrenches left on machine and any other conditions that may effect the machines operation. Repair and replace damaged parts.
- 20. Use recommended accessories.** Refer to instruction manual or ask correct service officer when using accessories. The use of improper accessories may cause the risk of injury.
- 21. Do not force machinery.** Work at the speed and capacity at which the machine or accessory was designed.
- 22. Use correct lifting practice.** Always use the correct lifting methods when using machinery. Incorrect lifting methods can cause serious injury.
- 23. Lock mobile bases.** Make sure any mobile bases are locked before using machine.
- 24. Allergic reactions.** Certain metal shavings and cutting fluids may cause an allergic reaction in people and animals, especially when cutting as the fumes can be inhaled. Make sure you know what type of metal and cutting fluid you will be exposed to and how to avoid contamination.
- 25. Call for help.** If at any time you experience difficulties, stop the machine and call you nearest branch service department for help.

# WARNING

## Motorised Sheetmetal Rolling Machine Safety Instructions

---

Machinery House  
requires you to read this entire Manual before using this machine.

- 1. Maintenance.** Make sure the Rolling machine is turned off and disconnect from the main power supply and make sure all moving parts have come to a complete stop before any inspection, adjustment or maintenance is carried out.
- 2. Rolling machine Condition.** Rolling machine must be maintained for a proper working condition. Never operate a Rolling machine that has damaged or worn parts. Scheduled routine maintenance should be performed on a scheduled basis.
- 3. Roll Condition.** Never operate a Rolling machine with a damaged or badly worn Rolls. Replace if required. Rolls should never be greased or lubricated as rolls will slip the material and will not bend.
- 4. Roll Direction.** Be aware of the correct Rotational axis of the motor when a qualified electrician connects the machine.
- 5. Hand Hazard.** Keep hands and fingers clear from moving parts. Serious injury can occur if hand or finger tips get pinched by rolls and can be dragged into machine.
- 6. Personal Protection.** Gloves, safety glasses and safety hat are recommended during operation.
- 7. Avoiding Entanglement.** Rolling machine guards must be used at all times. Tie up long hair and use the correct hair nets to avoid any entanglement with the Rolling machine moving parts.
- 8. Understand the machines controls.** Make sure you understand the use and operation of all controls.
- 9. Trained Operator.** This machine must be operated by authorized and trained personnel.
- 10. Power outage.** In the event of a power failure during use of the machine, turn off all switches to avoid possible sudden start up once power is restored.
- 11. Work area hazards.** Keep the area around the Rolling machine clean from oil, tools, chips. Pay attention to other persons in the area and know what is going on around the area to ensure unintended accidents.
- 12. Guards.** Do not operate Rolling machine without the correct guards in place. Necessary guards protect you from injuries by worm-type gearbox and other gears. The only other area which needs to be carefully monitored during use is the rotational area of the rolls.
- 13. Material condition.** Material must be clean out of oil and dry. Oily material can slip and will not bend.
- 14. Material hardness.** Make sure your hardness is the same throughout the material, we recommend that you use certified material. Never bend hard steel, glass or fragile material on this machine.
- 15. Feeding material.** Making a tight bend in one pass is not possible. So you need several passes before you can achieve a certain radius. Tighter curves and full radius always need more passes.
- 16. Stopping the Rolls.** Do not stop or slow the rolls with your hand or workpiece. Allow the Rolling machine to stop on its own.
- 17. Emergency stop.** Use the emergency stop button in case of any emergency.
- 18. Hearing protection and hazards.** Always wear hearing protection as noise generated from machine and workpiece can cause permanent hearing loss over time.
- 19. Call for help.** If at any time you experience difficulties, stop the machine and call your nearest branch service department for help.

# PLANT SAFETY PROGRAM

## **NEW MACHINERY HAZARD IDENTIFICATION, ASSESSMENT & CONTROL**

### **Motorised Sheetmetal Rolling Machine**

Developed in Co-operation Between A.W.I.S.A and Australia Chamber of Manufactures  
This program is based upon the Australian Worksafe Standard for Plant(NOHSC:1010-1994)

Item No.	Hazard Identification	Hazard Assessment	Risk Control Strategies <small>(Recommended for Purchase / Buyer / User)</small>
A	ENTANGLEMENT	HIGH	Eliminate, avoid loose clothing / Long hair etc.
B	CRUSHING	LOW	Secure & support work material. Ensure machine is bolted down.
C	CUTTING, STABBING, PUNCTURING.	MEDIUM	Isolate power to machine prior to any checks or maintenance being carried out. Do not adjust or clean until the machine has fully stopped. Wear gloves to prevent cuts from material.
D	SHEARING	MEDIUM	Isolate power to machine when checks or maintenance is being carried out. Make sure all guards are secured shut when machine is on. Hands should be kept clear of moving parts such as rolls etc.
F	STRIKING	MEDIUM	Ensure area is kept clear of material being rolled.
H	ELECTRICAL	MEDIUM	All electrical enclosures should only be opened with a tool that is not to be kept with the machine. Machine should be installed & checked by a Licensed Electrician.
O	OTHER HAZARDS, NOISE.	LOW	Wear hearing protection as required.

Plant Safety Program to be read in conjunction with manufactures instructions



[www.machineryhouse.com.au](http://www.machineryhouse.com.au)



[www.machineryhouse.co.nz](http://www.machineryhouse.co.nz)

Authorised and signed by:  
Safety officer:

Manager:

Revised Date: Aug-08